

NELSON™ HEAT TRACING SYSTEMS

SLT-LPS POWER CONNECTION KIT

INSTALLATION INSTRUCTIONS

DESCRIPTION

The SLT-LPS Entry Seal Kit provides a watertight entry into a junction box suitable for this application. This kit includes cable seals for power and end terminations. The SLT-LPS kit is designed for use with all versions of Nelson Heat Tracing Systems SLT and CLT-JT heater cables.

KIT CONTENTS

- 1 Cable Connector, .75" NPT thread
- 1 Conduit Locknut
- 1 Sealing Ring with Stainless Steel Retainer
- 2 Wire Nuts
- 2 Warning Labels
- 1 Shrink Tube, 12mm(.5") diameter, 76mm(3") length
- 2 Shrink Tube, 12mm(.5") diameter, 51mm(2") length
- 2 Shrink Tube, 3mm(.125") diameter, 25mm(1") length

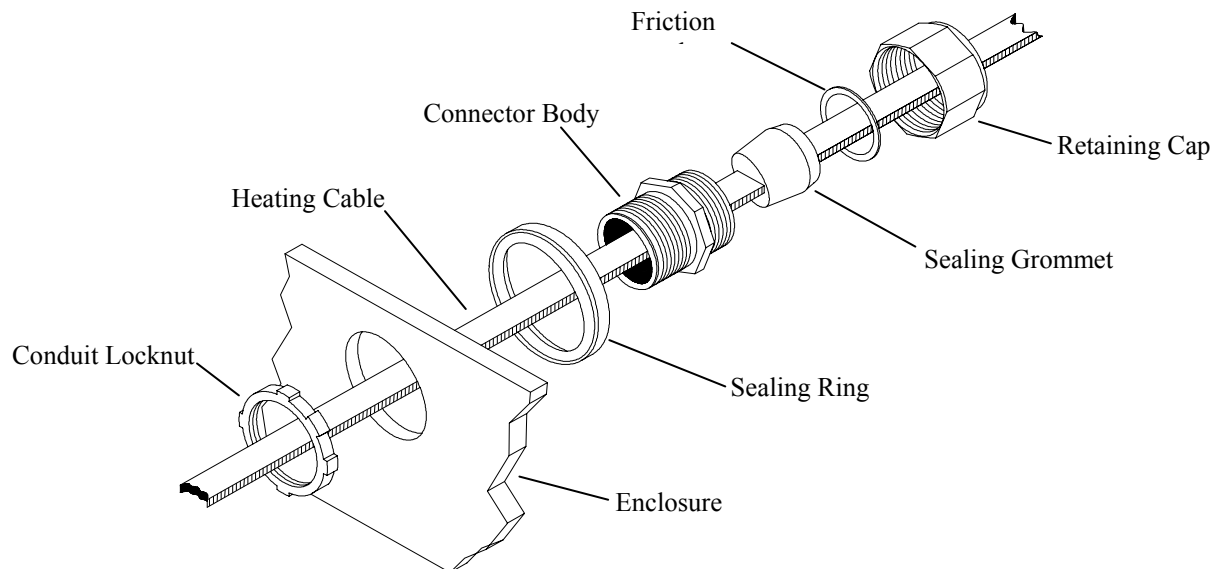

Note: This entry seal is suitable for use with any approved enclosure with a maximum wall thickness of .1875" or conduit outlet/junction box with .75" threaded hubs.

1. Install connector body on selected enclosure. For enclosures without threaded hubs, install the connector with the sealing ring on the outside and secure with the supplied locknut as shown in the diagram above. Discard these items when using threaded enclosures.
2. Slide the retaining cap, friction washer and grommet over the end of cable to be terminated.
3. Insert the cable through the connector body and into the junction box allowing enough cable to complete termination of the heating cable.
4. Tighten retaining cap securely to connector body. To avoid possible leaks, be careful not to over-tighten.
5. Terminate heater cable, see sheets 2-5.
6. Connect heater cable to power with supplied wire nuts.

WARNINGS:

- Article 426 of the National Electric Code requires that all outdoor electric deicing and snow-melting equipment be provided with branch circuit ground-fault equipment protection.
- If nuisance tripping of ground fault breakers occurs due to condensation in the junction box, electrical connections should be moisture proofed by use of a coating or sealant.

NELSON™ HEAT TRACING SYSTEMS

SLT-LPS POWER CONNECTION KIT

INSTALLATION INSTRUCTIONS

OVERJACKET STRIPPING PROCEDURES

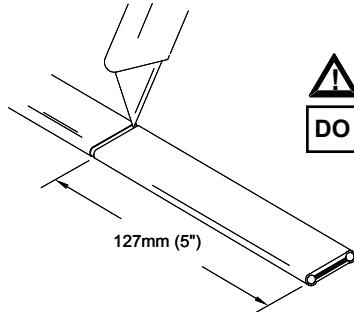

⚠ WARNING:
DO NOT CUT BRAID

- 1 Lightly cut around heater overjacket 127mm (5") from the end. Bend cable to break the overjacket.
- 2 Lightly cut overjacket up the center between first cut mark and the cable end. Bend cable to break the overjacket.

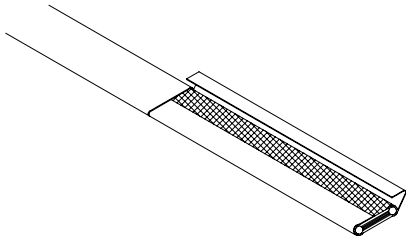

- 3 Remove overjacket from the heater cable.

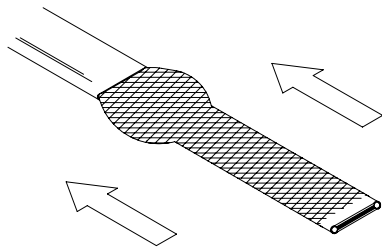

- 4 Move braid back toward the overjacket, creating a bulge.

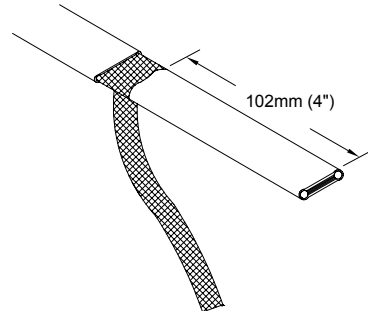

- 5 At the bulge, separate the braid to make an opening.

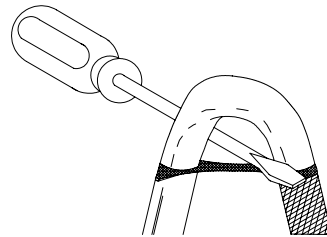

- 6 While bending the heater cable, work it through the braid opening.

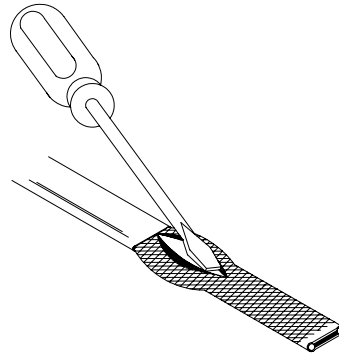

- 7 Pull the braid tight.
- 8 Proceed to "Outer Jacket Stripping Procedures", sheet 3 of 5.

NELSON™ HEAT TRACING SYSTEMS

SLT-LPS POWER CONNECTION KIT

INSTALLATION INSTRUCTIONS

OUTER JACKET STRIPPING PROCEDURES

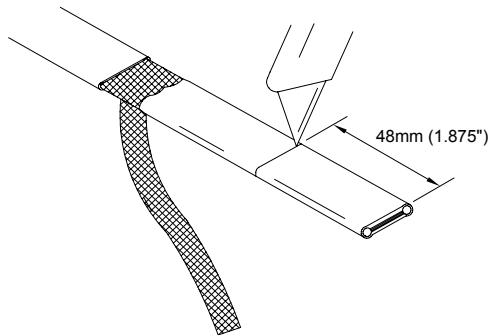

- 1 Lightly cut around heater outer jacket 48mm (1.875") from the end. Bend cable to break the outer jacket.
- 2 Lightly cut the outer jacket up the center between the first cut mark & cable end. Bend cable to break the outer jacket.

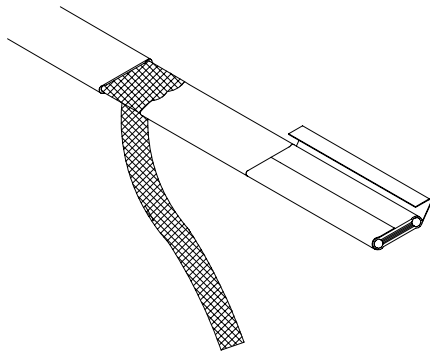

- 3 Remove jacket from the heater cable.

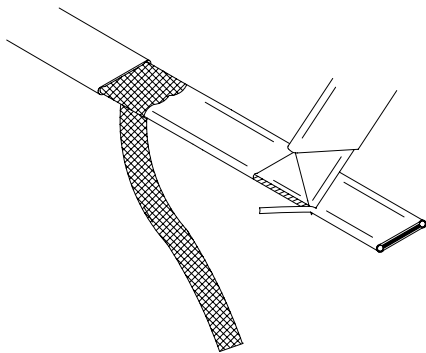

- 4 Shave the core material from the outside of each bus wire.

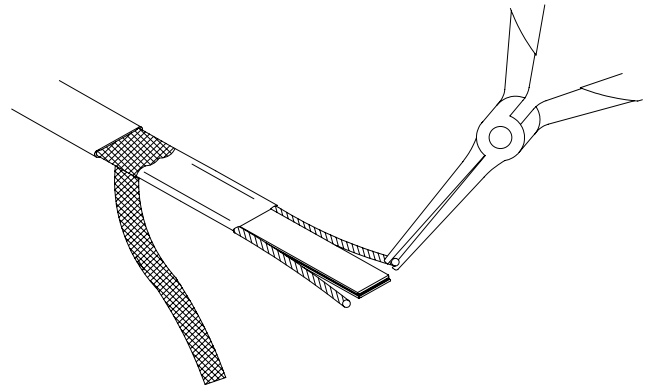

- 5 Starting at the end, pull each bus wire away from the core material.

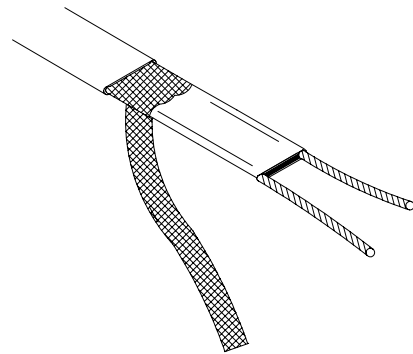

- 6 Remove exposed core material.
- 7 Proceed to "Shrink Tube Procedures", sheet 4 of 5.



WARNING:

DO NOT CUT BUS WIRES

NELSON™ HEAT TRACING SYSTEMS

SLT-LPS POWER CONNECTION KIT

INSTALLATION INSTRUCTIONS

POWER END SEAL SHRINK TUBE PROCEDURES

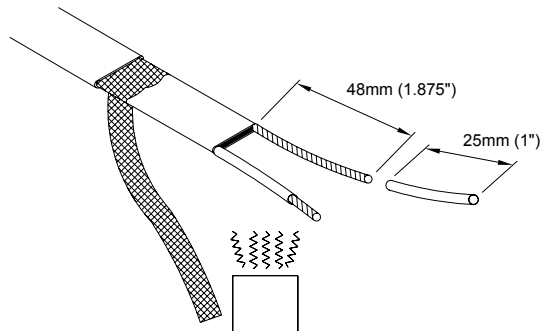

- 1 Slide one 3mm (.125") diameter, 25mm (1") length shrink tube over each bus wire, leaving approximately 13mm (.5") of each bus wire exposed. Shrink with heat gun until completely shrunk.

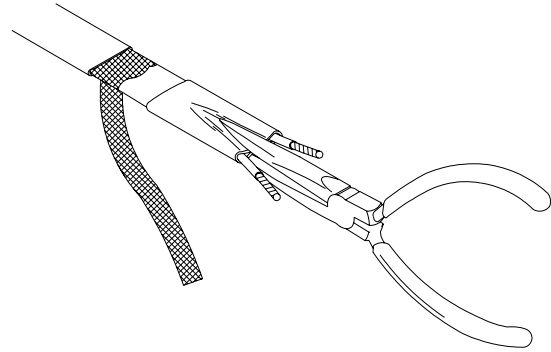

While still warm, spread bus wires and squeeze between them using needle-nose pliers, hold for 5 seconds. Allow power termination to cool before use.

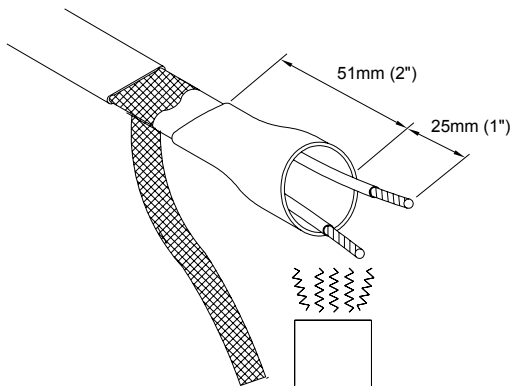

- 2 Slide one 12mm (0.5") diameter, 51mm (2") length shrink tube over both pigtail leads leaving approximately 25mm (1") of each pigtail lead exposed. Shrink with heat gun until completely shrunk.

NELSON™ HEAT TRACING SYSTEMS

SLT-LPS POWER CONNECTION KIT

INSTALLATION INSTRUCTIONS

END SEAL SHRINK TUBE PROCEDURES

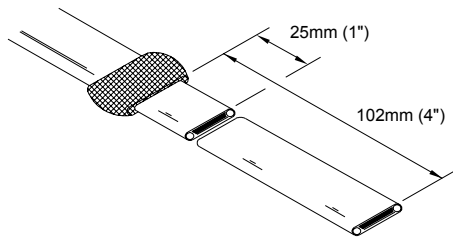

- 1 Cut heater cable off at required length. Strip overjacket back 102mm (4") from the end of heater cable. Slide braid back over the overjacket portion of the heater cable. Cut off excess heater cable leaving 25mm (1").

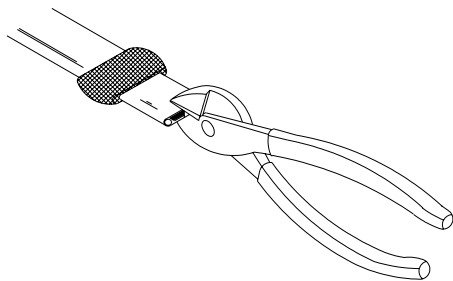

- 2 At the end of the heater cable, snip a 9.5mm (.375") slit between the bus wires. Slightly spread wires apart.

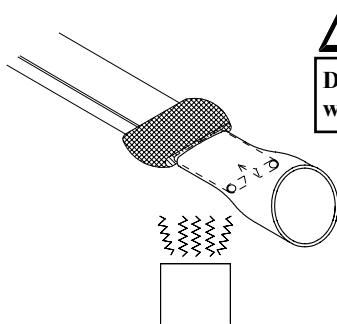

⚠ WARNING:
Do not overlap braid
with shrink tube.

- 3 Slide a 51mm (2") length shrink tube over the heater cable leaving 25mm (1") of shrink tube past the heater cable. Shrink with heat gun until completely shrunk.

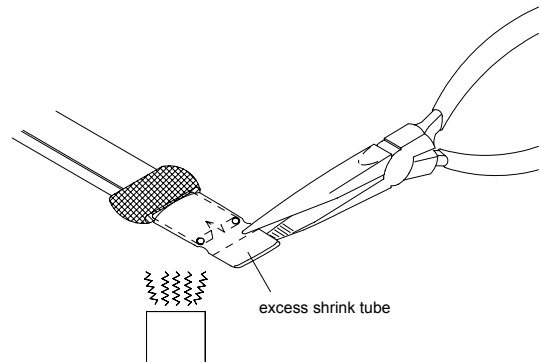

- 4 While still warm, squeeze the entire width of shrink tube closed. Cut off excess shrink tube.
- 5 Pull braid over the squeezed shrink tube, covering the entire end seal.

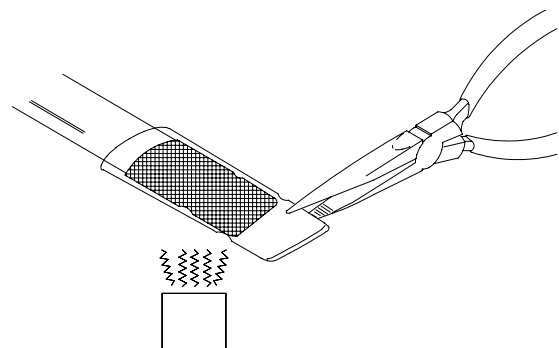

- 6 Slide a 76mm (3") length shrink tube over the braid leaving 12mm (0.5") of shrink tube past the braid. Shrink with heat gun until completely shrunk.
- 7 While still warm, squeeze the entire width of shrink tube closed.

Nelson Heat Tracing Systems products are supplied with a limited warranty. Complete Terms and Conditions may be found on Nelson's website at www.nelsonheaters.com.