



aef/fyi

SUMMER
2010



Toll-Free 877-803-9035 Fax 877-803-9129

THE OFFICIAL NEWSLETTER OF A.E.F. SALES ENGINEERING COMPANY

VOLUME 19
ISSUE 4

"America's
Favorite Newsletter"

JUNE 2010



Our 46th Year

CONTENTS:

NEW JERSEY SAVED!

The devastating storm in March wreaked havoc, but Central Moloney helped a local utility get its customers back online FAST. Here's how.

NEW, NEW, NEW!

The All-New Official AEF Sales website is ready for action.

GOLD MEDAL

How TEAM AEF helped the US Bobsled Team win Gold!

FOOLING EVERYBODY

Dutch painter Henricus van Meegeren thought he was as good a painter as any Old Master --- and he was.

ASK BERNADETTE

The World's Only Answer Cow helps our readers cope.

Central Moloney Rescues NJ



A few of the 600 Central Moloney Transformers that Saved New Jersey

March's SuperStorm did all kinds of damage; 60 mph winds knocked out power for half a million customers in AEF Land. New Jersey was hit especially hard: one local utility had 450,000 customers without power. The "worst storm in the company's history" was especially unkind to utility poles and the transformers mounted on them---over 350 poles were knocked down completely, and many others damaged.

The pole type transformers that needed replacing normally have a 4-6 week lead time, but with hundreds of thousands of customers in the dark, the utility needed transformers NOW. The buyer picked up the phone to Dennis VanVeckhoven, Central Moloney's Regional Sales Manager, hoping for a miracle. The result: Central Moloney came through Big Time: twenty hours after they hung up, the first transformers arrived. Within three days SIX HUNDRED beautiful transformers were sitting in a parking lot in New Jersey, ready to go. (Go to page 2)

New Website Makes Big Splash

IT'S HERE! The long-awaited, totally new, aefsales.com is open for business!

Some of the New Features: In-depth information on featured projects, with photos galore. More product information than ever, including details and specs, as well as data sheets and installation manuals in downloadable pdf formats.

For aef/fyi aficionados, who are legion, future issues of "America's Favorite Newsletter" will be available at the website. (Readers who have signed up for electronic delivery will get an e-mail notification with a link to aef/fyi, starting with our September issue.)

Also featured will be aef/fyi archives, including the very first issue from March 1988 (in glorious black on blue paper!) Many classic issues will be available for the first time in years!

All in all a website that is warm and cozy, young and happy, yet so packed with valuable technical information that you can read it while you'r at work and not feel guilty!

Why not drop everything and visit right now!



The graceful AEFettes make a Big Splash at Opening Ceremonies of the revamped AEF website!



The key to being a good manager is keeping the people who hate you away from the people who are still undecided.
Casey Stengel

Finding good players is easy. Getting them to play as a team is another story.
Casey Stengel

Let the one among you who is without sin cast the first stone.
John 8:7

Horse sense is the thing that keeps horses from betting on people.
W.C. Fields

If it's really a Miss Universe contest, why are there no contestants from other worlds? The whole thing is rigged so that Earth always wins.
Greg Easterbrook

Do the best you can, and don't take life too serious.
Will Rogers

Let everyone sweep in front of their own door, and the whole world will be clean.
Johann von Goethe

Look not at the face; look at the heart.
Quasimodo

EDITOR'S NOTE: *Reviewing our archives recently we came across this "Memo from Tony Fasolino" which was in our Winter 1989 issue. Since many of our readers today never had the chance to meet Tony, and since he set the tone for AEF's way of doing things, we thought we would share it with you.*

Besides, what was true in 1989 is still true in 2010.

As we begin 1989—our twenty-fifth year at A.E.F. Sales Engineering Company—we realize how much the electrical industry has changed.

Engineering consultants are designing and specifying systems and equipment that are more complex and more demanding of their time—systems and equipment that did not even exist twenty-five years ago. At the same time, competition forces reductions in the number of manhours available to complete these designs.

Constructors—the electrical and mechanical contractors— are installing, testing, and commissioning these same complex systems under increasingly competitive conditions.

Under these conditions, it is in the best interests of consultants, contractors, and end users that specifications clearly define the type and quality of equipment to be provided. All systems are not created equal.

Heater cable is an area where, without a doubt, there are differing quality levels on the market. Specifying a manufacturer does *not*

specify a level of quality. Would you go to a General Motors showroom, specify a four wheeled vehicle with an internal combustion engine, and buy a car? You might be thinking Cadillac—but buying Nova. **Quality specifications can save time and effort, since they avoid costly redesigns and change orders later.**

From the *contractor's* standpoint, it is obvious that equipment becomes more cost effective when installers get detailed, practical instruction from manufacturers' representatives. **The installed cost of equipment may be difficult to measure precisely, but it is what determines the profitability of a job.**

At A.E.F. Sales, we think that our methods of operation over the last twenty-five years have addressed the industry's needs. We provide detailed assistance in the design stage of a project and field-wise instruction and recommendations during the installation phase.

We want to be actively involved with your design and construction projects. We want your business, and we are willing to get it the old fashioned way. We want to earn it.

Miracle at the Meadowlands . . .

Many utilities have their suppliers put in summer 'storm stock', but summer stocking doesn't go into effect until May 1st (it's mainly a hedge against summer heat waves and the occasional hurricane) so the March storm really threw everyone for a loop.

So how the heck was Central Moloney able fulfill the utility's wild-est dreams, and give them what they needed to get their customers back on line? There are two simple reasons.

Unlike 99%* of transformer manufacturers out there, Central Moloney isn't owned by any Corporate Behemoth---it's 100% Employee Owned, which means they get to do whatever they want to do, whatever they need to do to take care of their customers. No powerpoint begging sessions trying to get the pezzonovante at Corporate to approve it.

Secondly CM is in the transformer and transformer components business, period. So when it comes to transformers, they know whereof they speak. And when they make a commitment to a customer nobody has to worry that some change in distant corporate winds will mean that a promise to perform will become "no longer operational".

Listening to what their utility customers need, and then doing whatever it takes to get it done. Worked out pretty good for that New Jersey utility --- and their customers.

You don't need a SuperStorm to be able to benefit from Central Moloney's experience and independence. Isn't a company that can deliver twelve tractor-trailer loads of transformers (almost) overnight the kind of company you'd like working for you?



Pulling a rabbit out of a hat is child's play. Try pulling 600 transformers out of thin air!

*Roughly



Bernadette
The AEF Sales Answer Cow

DEARBERNADETTE:

I had some problems with a heat tracing system we're installing. I got NO help from the vendor---when he finally returned my calls I had to beg, plead, cajole and threaten him before he agreed to come take a look. When he finally did show up, he wasn't gonna be allowed on the jobsite without an escort. Guess who pays for the escort? I'm getting so fed up trying to do business anymore that going into that Alpaca farm with my brother-in-law is looking better and better. Thanks for letting me vent. A.R.

DEAR A.R.:

From the very first words of your letter I knew you did not have TEAM AEF as your heat trace supplier. That's too bad; they could have saved you a lot of

agita, for two good reasons.

First off, a lot of the time there's just no substitute for being on site, and TEAM AEF has spent over forty-six years crawling and climbing around every kind of site you can imagine, and quite a few you can't.

Secondly TEAM AEF has a TON of certifications: PATH, TSA, the Defense Department, the NYC Fire Department, SWAC --- so there's NO jobsite where they need an expensive babysitter. A lot of these certifications require biometric credentials, special training, background checks and so forth, which takes time, energy, and money. Most suppliers can't be bothered---why go through all that when they can just get a security escort on the customer's dime? For AEF it's just another facet of Legendary Service.

You know who to call next time, right?

DEARBERNADETTE:

What exactly is a joule, and where did the word *joule* come from? A.W.

DEAR A.W.:

A joule is the amount of energy required to pass an electric current of 1 amp through a 1 ohm resistance. The term 'joule' comes from the English physicist James P. Joule. His name is one of many electrical pioneers whose names have become part of electrical terminology, including James Watt, Francis Volt, Mary Lou Amp, and Bob Transformer.

If the pen is mightier than the sword in a duel I'll let you have the pen.
Steven Wright

When you got nothin', you got nothin' to lose.
Bob Dylan

Learn to separate life's inconveniences from real problems. You will live longer, and you will not annoy people so much.

Sigmund Wollman

You can't always get what you want; but if you try sometime you just might find you can get what you need.

The Rolling Stones

Are You Getting Everything You Should Get?

Most heat trace suppliers are content to send out some boxes of heat trace and an invoice. Not AEF.

TEAM AEF figures that the information needed to do the job fast, and right, is part of what we owe our customers.

If we provide a panel as part of the job we don't just ship a panel, we ship a drawing like this so the installer knows exactly which circuit goes to what breaker --- that saves TIME and MONEY, makes for a better installation, and provides a reference document for the building owner.

AEF keeps electronic copies on our server, so all that information will always be there if and when its needed.

So if you bought a panel, and got just a panel, you didn't get it from us.

In today's tough business climate you need every edge you can get; and that's what we aim to deliver, every job, every time.

Our customers deserve it.

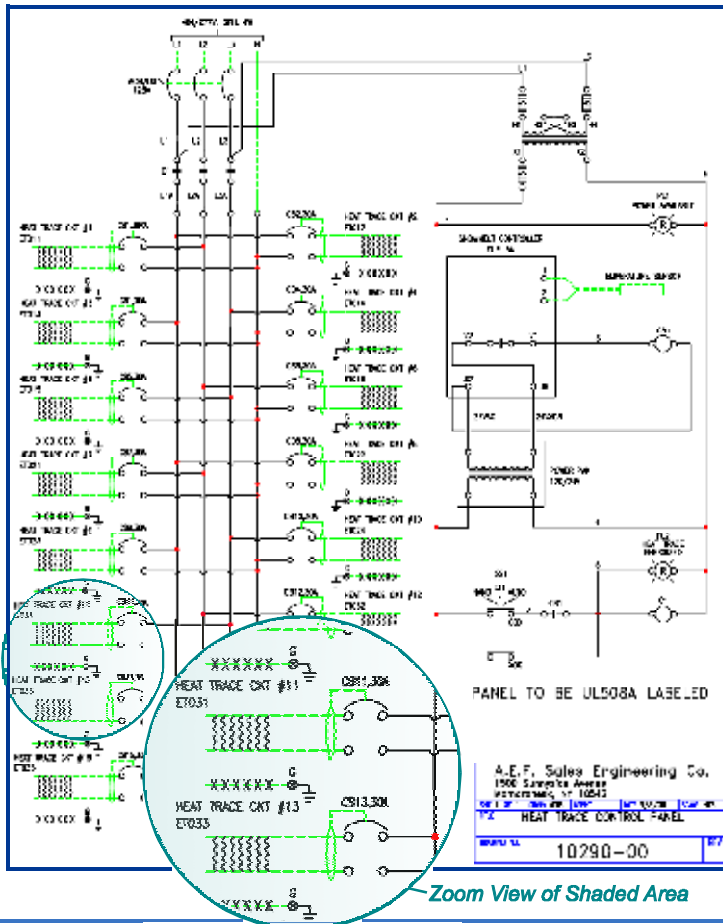

To think outside the box you have to be willing to think.

Dooms Madigan

Politicians like to see themselves as heroic figures grappling with the world's problems, but in reality are incapable of achieving anything beyond the misuse of public money.

Leo McKinstry

The only difference between death and taxes is that death doesn't get worse every time Congress meets.

Will Rogers

Life is very short, and there's no time for fussing and fighting, my friend.

The Beatles

Unoriginal



Self Portrait - 1935

Henricus van Meegeren was the most famous and successful art forger ever; so good, in fact, that if he hadn't confessed to his forgeries they would never have been discovered.

Van Meegeren was born in Holland in 1889. By the 1920's he was doing what most artists never do, making a good living as a sought-after portrait artist. Not satisfied with doing portraits of wealthy customers, he wanted recognition of what he felt

was his talent as an artist. He felt he was just as good as many of the Old Masters whose work hung in museums, but the art world didn't agree. In 1932 he began work on his first forgery, a copying a masterpiece of the Dutch artist Vermeer. It turned out pretty good; in fact it was bought by a museum in Rotterdam, and for many years was considered Vermeer's finest work.

Revenge was not only sweet, it was lucrative; his fakes sold at auctions for as much as \$495,000 (in 1930's dollars). During World War II one happy customer was Nazi Hermann Goering, and this was van Meegeren's undoing. Because of the sale, he was charged in 1945 with collaborating with the Nazis for turning over a 'national treasure' to the Nazis, and faced the death penalty.

He pleaded innocent, claiming he gave up nothing of value, since he had painted the Vermeer himself. The Dutch authorities and the art world weren't buying that, but it was decided to give him a chance to prove his claim --- by painting another 'Vermeer' in prison. The new 'Vermeer' was good enough for the charges against him to be reduced to forgery, and he was sentenced to one year in prison.

Van Meegeren died in prison one month into his sentence, and a lot of Vermeer masterpieces quietly disappeared from museums around the world.

Guess he was a pretty good painter after all.

Backwords

GREEN, GREENER, GREANEST

What's the greenest way to replace a transformer? Have it rebuilt by R.E. Uptegraff. This makes a whole lot of environmental sense, since still useful materials such as the core, tanks, etc., can be re-used instead of being scrapped. Going green this way can save you 30% over the cost of a new unit.



Goose Clothes for All Occasions

While doing exhaustive research for this issue we came across numerous websites offering quality, affordable geese clothes. Clothing is available for plastic, cement, and fabric geese. Along with casual wear and dressier outfits, there are geese clothes for every season, and every conceivable special occasion. If your plastic, cement, or fabric goose is getting married, graduating, joining the military, or pursuing an interest in sports, you can rest assured you'll be able to provide just the right look. Prices start at \$10 and run upwards of \$50.

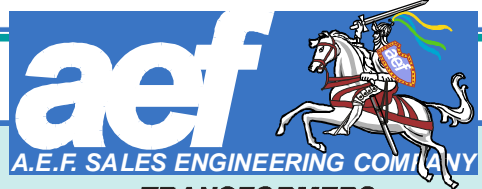

TRANSFORMERS Central Moloney

www.centralmoloneyinc.com

Single Phase Transformers: Pole Type, Padmounted, Vault, and Stepdown
Three Phase Padmounted Transformers
Components: Bushings-Switches-Accessories
JSRP Job Site Ready Padmounts

R.E. Uptegraff Manufacturing

www.uptegraff.com

Liquid Filled Transformers to 20mva
Subsurface, Load Center, Station Type
Rectifier Applications, Zig Zag Grounding
Phase Changing and Phase Shifting
Traction Power, Current Limiting Rectifiers
Rebuilding and Rewinding Services

HEATER CABLE & CONTROLS

MI Cable for Pipe Tracing & Snowmelting
Self-Regulating Cable for Pipe Tracing
Hot Water Maintenance Cable
Self-Regulating Cable for Roof & Gutter De-icing
Electronic & Mechanical Thermostats & Controls
Heat Trace Monitoring Systems
Microprocessor Based Heat Trace Control

Heat Tracing Since 1964

Toll-Free 877-803-9035 Fax 877-803-9129

USA! USA! USA! AEF! AEF! AEF!



Astute readers will remember the lead story in our last issue about how the U.S. Bobsled Team had turned to TEAM AEF to solve some serious roof and gutter ice problems at their Lake Placid equipment building.

The results? The happy US Bobsledders no longer had to worry about chunks of ice falling on their heads when they worked on their sleds! And, oh yeah, a **GOLD MEDAL** for the four man team at Vancouver.

At the end of March AEF's Peter Fasolino visited the site to meet with John Donahue, who had supervised the installation, and John Morgan, who directed the American bobsled effort.

Morgan expressed his and the teams' thanks, and presented Mr. Pete with autographed photos of the team. While he didn't exactly say that TEAM AEF was directly responsible for the Gold Medal win, we are fairly certain that is what he meant.

But we couldn't have done it without them.